

Part No. (Fig 1)	Torque(gf. cm)	Paint Mark
DMP-A1-01	25±8 R/M	White
DMP-A1-02	40±10 R/M	Yellow
DMP-A1-03	60±10 R/M	Purple
DMP-A1-04	80±15 R/M	Green
DMP-A1-05	120±15 R/M	Black
DMP-A1-06	130±15 R/M	Blue
DMP-A1-07	150±15 R/M	Red

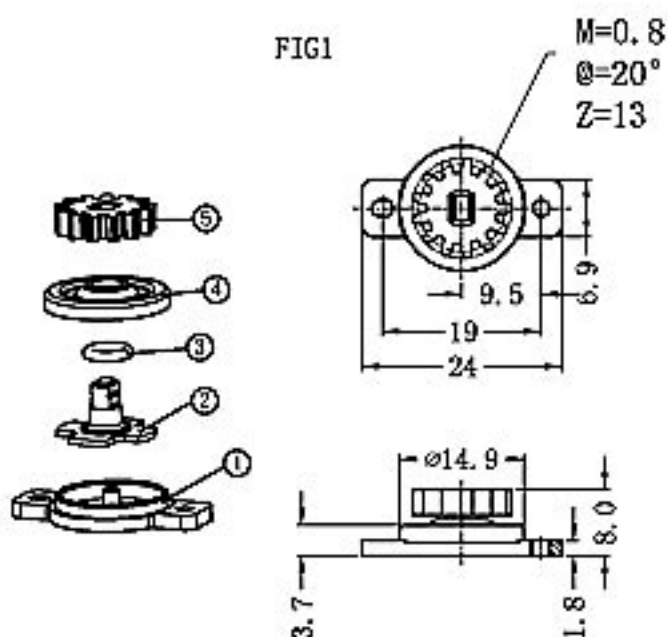

5	GEAR	PMN	1	
4	CAP	ABS	1	
3	RING	SI	1	
2	SHAFT	PMN	1	
1	CASE	ABS	1	
ITEM	PART-NO	MATERIAL	QTY	REMARK

NYLON FASTENERS LTD

DATE 2009-02-09 Dimension Tolerance

SCALE FIT L≅4 ±0.10

TITLE	Damper	MOLD-NO.		DRAW	CXS	UNIT	MM	4<L≅15	±0.20
NO.	DMP-A1	MAT.		DESIGN	HLR	REV.	A0	15<L≅50	±0.30
COMPUTER				APPR.		VIEW		50<L≅100	±0.40